

Article number: 20820275MF
 Description: E+G horizontal clamps
 GN 820.2-75-MF

Measures

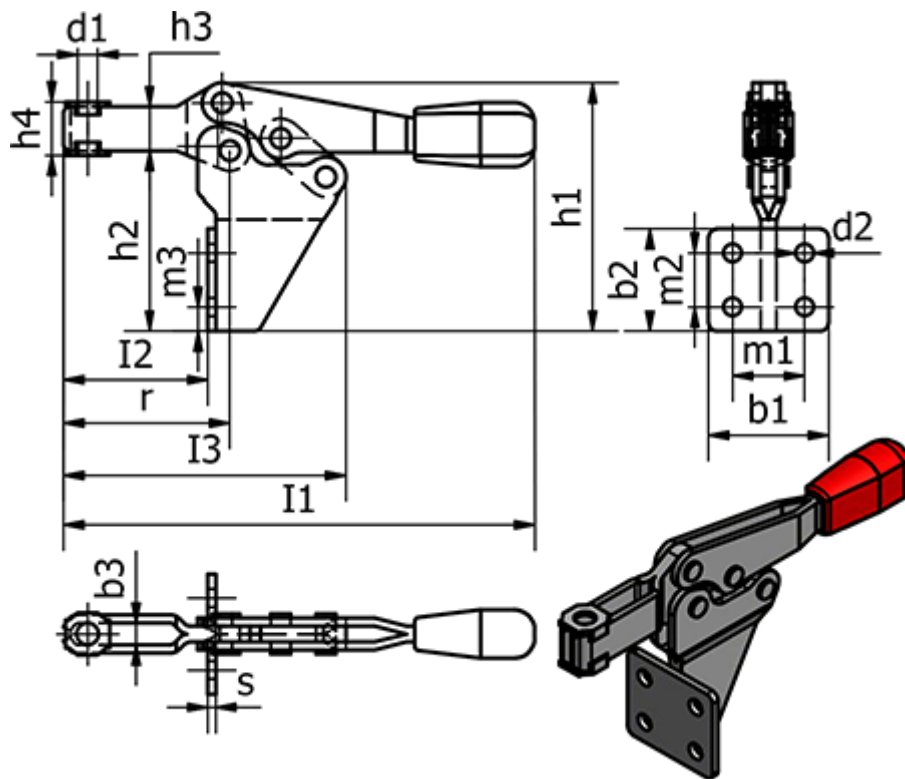

b1 = 30	h4 = 22.5	r = 42.5
b2 = 25.5	Holding force in N = 900	s = 2
b3 = 5.5	l1 = 118	Wight (g) = 105
d1 = M5	l2 = 30	
d2 = 4.5	l3 = 72	
h1 = 62	m1 = 18	
h2 = 39	m2 = 13.5	
h3 = 11	m3 = 6	